

Plascore AltuCore™



Lightweight Energy
Absorption

High Strength, Cylindrical Energy Absorber

Plascore **Aluminum Tubular Core** AltuCore™ is a lightweight, high-strength core manufactured in an annular cylindrical shape which is well suited for single-use energy absorption applications. AltuCore™ yields at a constant force providing reliable and consistent energy absorption for applications with in-axis loading conditions.

Features

- Energy absorption in a cylindrical shape
- High crush strength-to-weight ratio
- Efficient constant force crush curve
- Wide range of strengths available
- Typical crush stroke is 60% of length
- Excellent moisture and corrosion resistance
- Elevated use temperatures

Applications

Aerospace – A lightweight single-use energy absorber for attenuating impacts, controlling maximum loads, and over-travel protection.

Defense – Can serve as a crushable member to mitigate dynamic events.

Dynamic Testing – For high G load testing of components.

Industrial Safety – Provides efficient high-load drop or overload protection to prevent equipment failure.

Shipping Protection – Precise crush strength and high service temperatures facilitate use in many environments with minimal impact on the shipping weight.

Transportation – Attenuates impact in applications where lightweight, high-performance energy absorption is critical for safety.

Availability

AltuCore™ is custom manufactured in a wide range of strengths and sizes. Available as load certified in precrushed form or in stock lengths.

Outside Diameter:	1" - 16" (typical)
Inside Diameter:	0.375" Minimum
Length:	21" Maximum
Crush Strength:	1000 - 8000 psi
Crush Stroke:	55% - 70% (depending on strength)
Available Alloys:	3003, 5052, 5056

Contact a Plascore Representative for assistance specifying this material for your particular application and requirements.

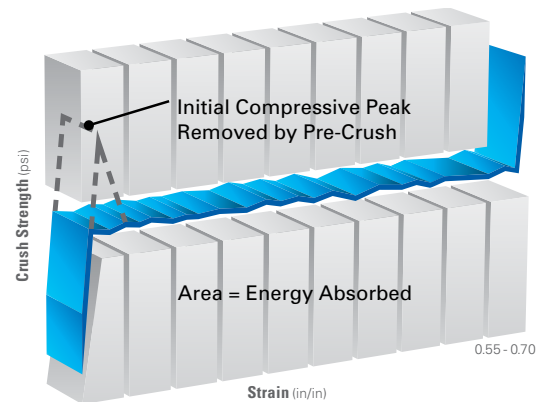

Constant force vs. displacement curve provides efficient lightweight energy absorption unique to aluminum honeycomb

Application Examples

AltuCore in cylinder

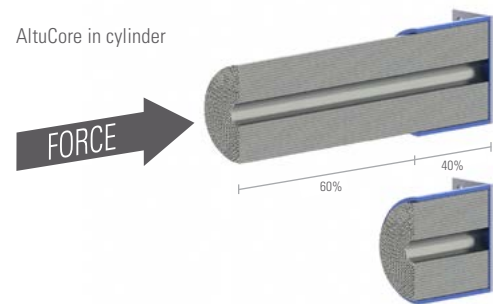

AltuCore used for tensile force

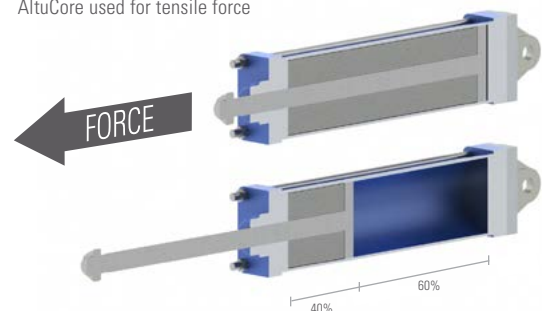

PLASCORE®

Properties

A range of static crush strengths from 1000 - 8000psi can be manufactured.

- Dynamic crush strengths can be 10% - 40% higher depending on strength and impact velocity. AltuCore™ should be evaluated by dynamic test in the final configuration to verify dynamic performance.
- Crush strokes as high as 70% are available, decreasing to 55% for higher strength core.
- AltuCore™ will crush and fold upon itself uncontained to strengths of 2500psi. Higher strengths should be contained within a cylinder, crushed into a cap, or wound with a composite wrap for best performance.

Testing

AltuCore™ is precrushed to eliminate the initial compression peak load. During this operation, average load is recorded to show conformance to crush strength requirements.

While the information contained herein is believed to be reliable, no warranty is expressed or implied regarding the accuracy of the data or the results to be obtained thereof. All recommendations or suggestions for use are made without guarantee inasmuch as conditions for use are beyond our control.

Crush Strength

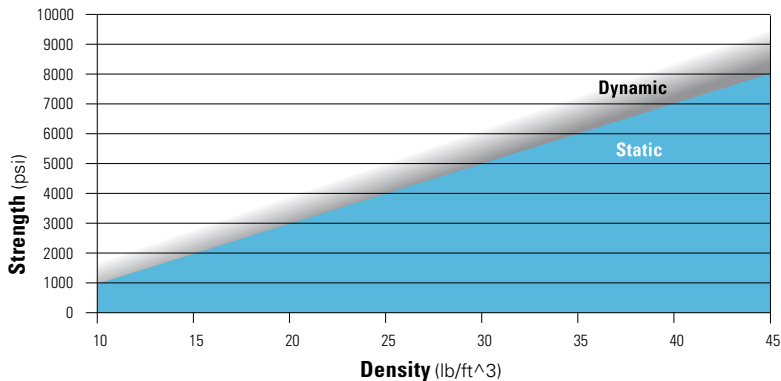

Effective Stroke

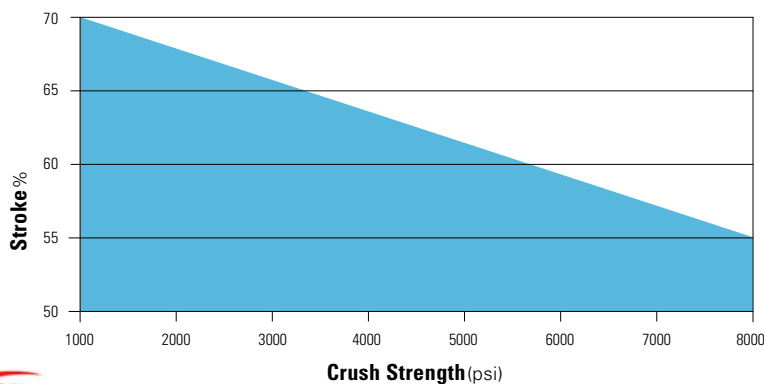

Plascore, Inc., employs a quality management system that is ISO 9001 and ISO 14001 certified.

IMPORTANT NOTICE: The information contained in these materials regarding Plascore's products, processes, or equipment, is intended to be up to date, accurate, and complete. However, Plascore cannot warrant that this is always the case. Accordingly, it is a purchaser's or user's responsibility to perform sufficient testing and evaluation to determine the suitability of Plascore's products for a particular purpose. Information in these materials and product specifications does not constitute an offer to sell. Your submission of an order to Plascore constitutes an offer to purchase which, if accepted by Plascore, shall be subject to Plascore's terms and conditions of sale. PLASCORE MAKES NO WARRANTIES OF ANY KIND REGARDING THESE MATERIALS OR INFORMATION, EITHER EXPRESS OR IMPLIED, INCLUDING WITHOUT LIMITATION THE IMPLIED WARRANTIES OF MERCHANTABILITY AND FITNESS FOR A PARTICULAR PURPOSE. Plascore owns and shall retain all worldwide rights in its intellectual property, and any other trademarks used in these materials are the property of their respective owners. The information in these materials shall not be construed as an inducement, permission, or recommendation to infringe any patent or other intellectual property rights of any third parties. © 2021 Plascore, Inc. All Rights Reserved. v04.6.2021



AltuCore™ absorbs energy by crushing under load



Corporate Headquarters

Plascore Incorporated

615 N. Fairview St.
Zeeland, MI 49464-0170
USA

Phone (616) 772-1220
Toll Free (800) 630-9257
Fax (616) 772-1289
Web www.plascore.com
Email sales@plascore.com

Europe

Plascore GmbH & Co KG

Feldborn 6
D-55444 Waldlaubersheim
Germany

Phone +49(0) 6707-9143 0
Fax +49(0) 6707-9143 40
Web www.plascore.de
Email sales.europe@plascore.de



PLASCORE®