

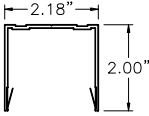

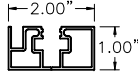

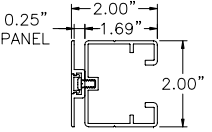

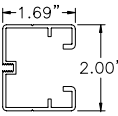

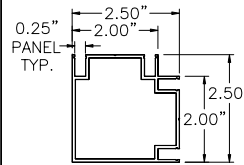
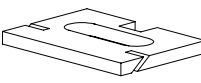
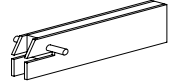
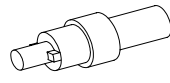

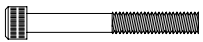

THIS DOCUMENT CONTAINS PROPRIETARY INFORMATION WHICH MAY NOT BE DISCLOSED TO OTHERS FOR ANY PURPOSE WITHOUT WRITTEN PERMISSION FROM PLASCORE INC.

S5050

PROJECT NAME: _____
 SUBMITTAL REVISION: _____
 DATE: _____
 APPROVED BY: _____

 <p>55mmx2" Head Track Assy 871001 Assy w/gasket 871011 Welded Corner</p> <p>831932 Head Track 55mm x 2" 33774 HT Gasket</p> <p>Other styles also available</p>	 <p>S5050 Floor Track Assy 831937 w/ 0 inserts 871022 w/ 1 insert 871021 w/ 2 inserts</p> <p>831937 F5050 Floor Track 831974 Threaded Insert</p>	 <p>S5050 Post w/Batten Assy 871024 w/ 0 plates 871002 w/ 1 plate 871003 w/ 2 plates</p> <p>831935 S5050 Post 831085 2" Shallow Batten 830606 Enclosure Cap 831923 Fastening Plate 868006 Batten Screw</p>	 <p>S5050 Post Assy 831935 w/ 0 plates 871018 w/ 1 plate 871019 w/ 2 plates</p> <p>831935 S5050 Post 831923 Fastening Plate</p>			 <p>S5050 Corner Post 831737 Corner Post</p>																			
 <p>831923 Fastening Plate</p>	 <p>831959 Crimping Tool for Fastening Plate 831923</p>	 <p>831973 Installation Tool for Threaded Insert 831974</p>																							
 <p>868006 PPH 10-24 x 5/16 Batten Screw</p>	 <p>868008 PPH 10-24 x 7/16 Screw @ FT T-intersect</p>	 <p>840806 BSHSCS 5/16-18 x 5/8 T-Bolt @ Fastening Plate</p>	 <p>868012 SHCS 1/4-20 x 2 Bolt @ FT threaded insert</p>	 <p>868011 PH Torx Tapping 10x1-1/2 Screw @ FT & S5050 Corner</p>	 <p>840681 Flat Washer 1/4" Flat Washer @ FT & S5050 Corner</p>	 <p>831974 Threaded Insert</p>																			
 <p>840807 T-Nut 5/16-18 T-Nut @ Fastening Plate</p>	 <p>840803 T-Nut 1/4-20 T-Nut @ Threaded Insert</p>	 <p>xxx Aligning Block FT @ F5075 Corner</p>	 <p>1216 Aluminum Bar 1/4"x1/2" Used @ Wall End</p>	<p>UNLESS OTHERWISE SPECIFIED, DIMENSIONS ARE IN INCHES AND TOLERANCES ON:</p> <p>XXXXX = CRITICAL DIM LEVEL 2 XXXXX³ = CRITICAL DIM LEVEL 3</p> <p>FRACTIONS: = ± 1/16 DECIMALS: X=±0.1 .X=±0.06 .XX=±0.03 .XXX=±0.01</p> <p>ANGLES: = ± 2'</p> <p>CAD# MATRIX S5050</p>	<p>PLASCORE 615 N. FAIRVIEW STREET ZEELAND, MICHIGAN 49464 (616) 772-1220</p> <p>DWG TITLE COMPONENTS FOR S5050 WALL SYSTEM</p> <table border="1"> <tr> <td>SIZE</td> <td>FSCM</td> <td>DWG NUMBER</td> <td>REV</td> </tr> <tr> <td>A</td> <td>39212</td> <td>MATRIX S5050</td> <td>-</td> </tr> <tr> <td colspan="2">DRAWN BY: A. SCHOUMAN</td> <td colspan="2">DATE: 11/22/02</td> </tr> <tr> <td colspan="2">ENGRG:</td> <td colspan="2">QC APP.</td> </tr> <tr> <td colspan="2">SCALE: NTS</td> <td colspan="2">SHEET: 1 OF</td> </tr> </table>	SIZE	FSCM	DWG NUMBER	REV	A	39212	MATRIX S5050	-	DRAWN BY: A. SCHOUMAN		DATE: 11/22/02		ENGRG:		QC APP.		SCALE: NTS		SHEET: 1 OF	
SIZE	FSCM	DWG NUMBER	REV																						
A	39212	MATRIX S5050	-																						
DRAWN BY: A. SCHOUMAN		DATE: 11/22/02																							
ENGRG:		QC APP.																							
SCALE: NTS		SHEET: 1 OF																							
<table border="1"> <tr> <td>REV.</td> <td>DATE</td> <td>DESCRIPTION</td> <td>SIGNATURE</td> </tr> <tr> <td> </td> <td> </td> <td> </td> <td> </td> </tr> </table>	REV.	DATE	DESCRIPTION	SIGNATURE																					
REV.	DATE	DESCRIPTION	SIGNATURE																						